



The ROKK 1 Series high pressure homogenisers and piston pumps have excellent performance and reliability in the latest design concept.

ROKK 1 Series homogenisers / piston pumps are available with capacities from 20 - 50 litre / hour up to 1600 bar as one stage or double stage depending on application.

Application Fields



DAIRY PRODUCTS

Milk
Yoghurt
Ice Cream
Cream
Cheese
Dessert



PHARMACEUTICALS

Antibiotics
Creams
Antacids
Tablet Coatings
Liposomes
Ointments



FOOD AND BEVERAGE

Fruit Juices
Ketchup / Tomato Paste
Baby Foods
Peanut / Hazelnut Paste
Honey / Chocolate
Tahina



CHEMICALS

Paint
Detergents
Soap
Waxes
Lubrication Oil
Paraffin Emulsions



COSMETICS

Hair Products
Skin Creams
Lipsticks
Lotions
Shampoos
Nail Polishes



BIOTECHNOLOGY

Proteins
Yeast
Vitamins
Bacteria
Enzymes
Viruses

The Principle of Homogenisation

The unhomogenised product enters the valve area at high pressure and low velocity. As the product enters the adjustable, close clearance area between the valve and the seat, there is a rapid increase in velocity with a corresponding decrease in pressure. The intense energy release causes turbulence and localised pressure differences, which tear apart the particles. The homogenised product impinges on the impact ring and exits at a pressure sufficient for the next processing stage.

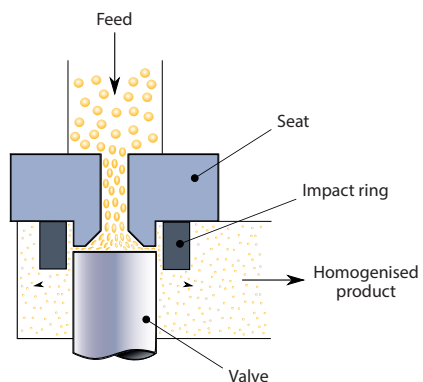

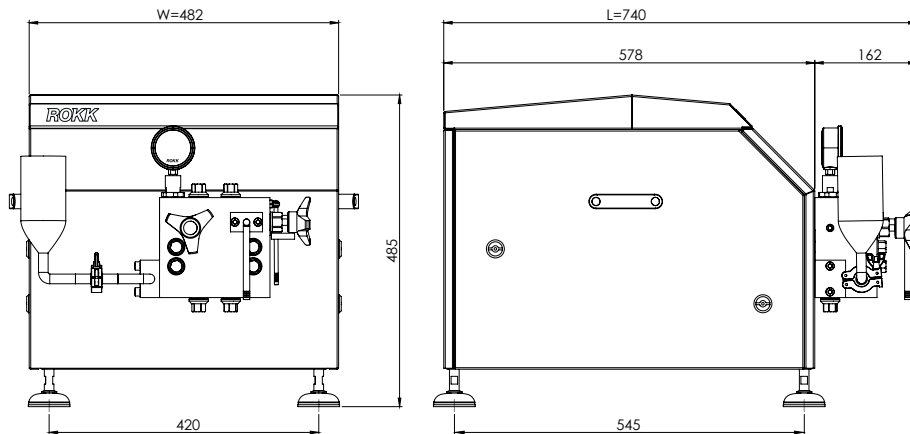

Technical Features

Number of Plungers	2	Lubrication Oil ISO VG 150	1.5 l
Weight	110 kg.	Motor Power	2.2 kW

Manufacturing Location



MonoBlock

The MonoBlock (compression head) is manufactured out of a high tensile, corrosion resistant, forged, ultra-high quality stainless steel and checked for imperfections using ultrasound equipment. The compression head for sanitary applications provides an in-line flow pattern and minimises the number of sealed areas. The semi-spherical valves system allows smooth machine operation, for both low and high viscosity products.



Machine Features

- Designed according to the EU safety rules (CE standards)
- Engineered, manufactured and tested according to ISO EN 9001 Quality System
- Engineered and designed for easy maintenance and cleaning (CIP and SIP)
- Suitable for abrasive and viscous products
- Ceramic coated stainless steel plungers
- Cobalt carbide material suction and delivery valves & valve seats
- Tungsten Carbide homogenising valves
- Compression Monoblock head formed by single forged block in special stainless steel
- Automatic homogenisation pressure controller with manual adjustment
- Stainless steel construction (Frame) and electrical panel board
- Less footprint with ergonomic design
- Sanitary design analogue diaphragm high pressure gauge
- V belts drive train and gearbox speed reduction unit
- AC motor drive

ROKK Processing Ltd

Wolvey Lodge Business Centre, Cloudsley Bush Lane, Wolvey, Leicestershire, LE10 3HB, England
 T. +44 (0)1455 220 179 F. +44 (0)1455 221 314 E. sales@machineryworld.com